

Change-over for Central Supplies

SIM240 Static Inverter Module

On medium to large projects it can be advantageous to provide emergency lighting using a static inverter connected to a number of the existing mains luminaires.

In these installations it may be necessary for the normal supply and the static inverter supply to be selected by an automatic switching device within or external to the luminaire. Some suppliers offer a standard 230V AC change-over relay for this purpose but this ignores the fact that a free running static inverter is not tied to the grid frequency and will therefore be out of phase or in a worst case situation could be in anti-phase with the normal switched supply. When a relay tries to switch between these supplies there is a tendency for the relay to suffer from arcing between the normally open and the normally closed contacts resulting in a temporary short circuit between the two out of phase supplies. This will cause external circuit protection to operate (fuses and/or circuit breakers) and will ultimately destroy the relay. In extreme cases it can also damage the static inverter.

OPERATION

The **SIM240** static inverter module is designed to eliminate these switching problems.

The SIM240 utilises two interposing relays for the two supplies and introduces a time delay greater than 0.5s between breaking the normal supply and connecting the static inverter supply.

This sequence is reversed upon restoration of the monitored 230 volt supply when the **SIM240** immediately breaks the static inverter supply and then after a similar time delay reconnects the normal lighting supply.

A dimming isolation facility is incorporated as standard for use with dimming drivers to enable full light output to be achieved in the emergency condition.



GENERAL SPECIFICATION

Supply Voltage	230Volt (220-240V) ~ 50Hz
Supply Current	18mA
Temperature Range	0 to 70°C
Relays	2 x DPCO plus 1 x SPCO
Time Delay on Changeover	Greater than 0.5s
Relay Rated Voltage	240V AC
Relay Rated Current	4A maximum
Dimensions	32mm (H) x 42mm (W) x 160mm (L)

Emergency Lighting Products Limited
Parbrook House, Cillmans Industrial Estate,
Natts Lane Billingshurst, West Sussex RH14 9EZ

Telephone: +44 (0) 1403 786601
Fax: +44 (0) 1403 786602
e-mail: sales@elp.uk.com

Safe in the knowledge
elp.uk.com

SIM240 Static Inverter Module

SCHEMATIC – SIM240

(CIRCUIT SHOWN IN MAINS INPUT HEALTHY MODE)

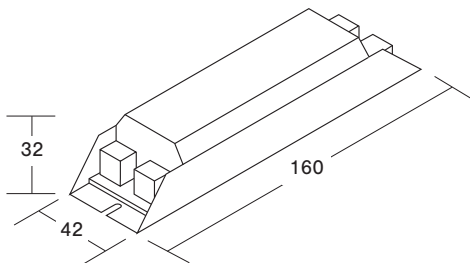
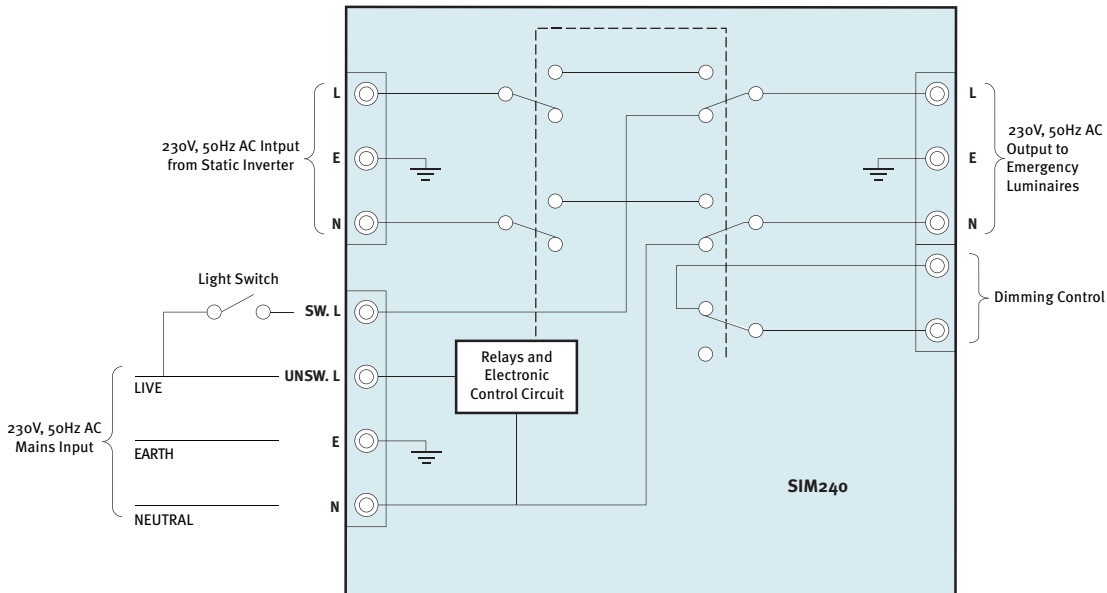

FIXING CENTRES:
152mm

ORDER CODE	Description
SIM240	Change-over module for central supply systems

Emergency Lighting Products Limited
Parbrook House, Cillmans Industrial Estate,
Natts Lane Billingshurst, West Sussex RH14 9EZ

Telephone: +44 (0) 1403 786601
Fax: +44 (0) 1403 786602
e-mail: sales@elp.uk.com

Safe in the knowledge
elp.uk.com